

begane grond

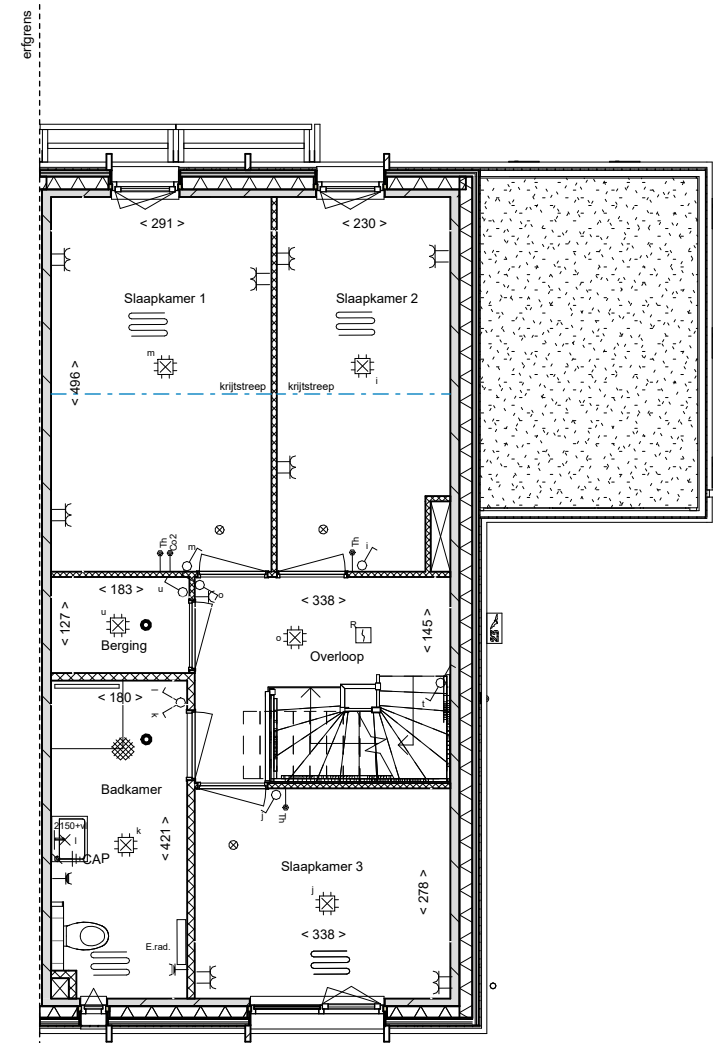

eerste verdieping

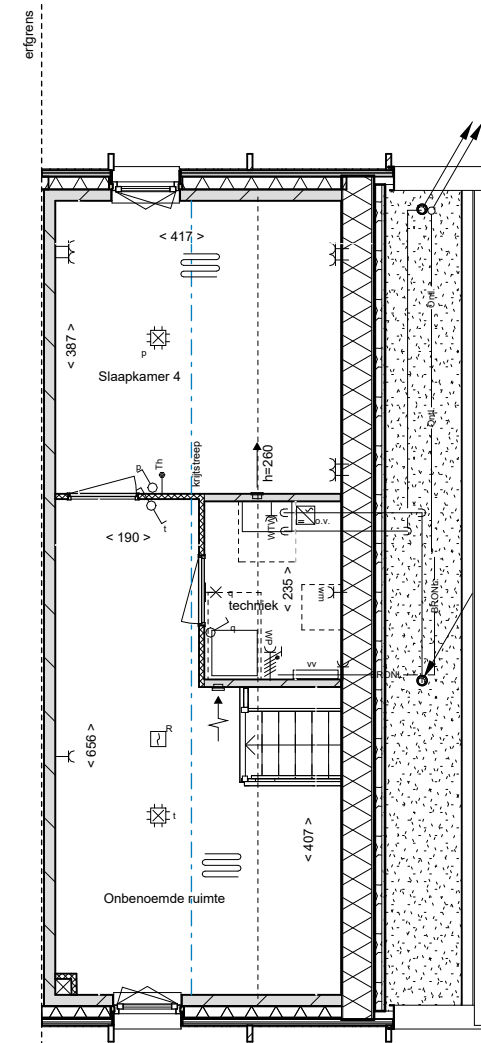

zolder

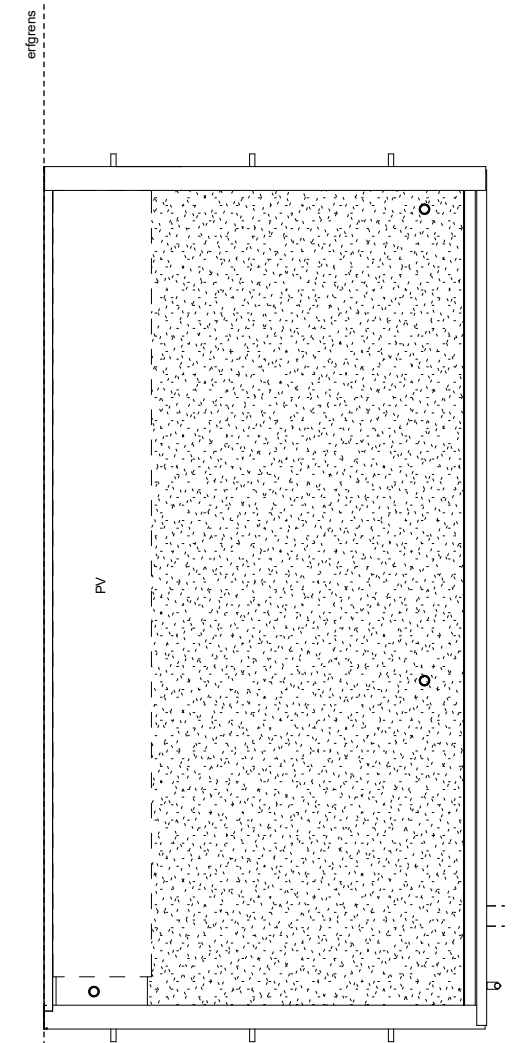

dakaanzicht

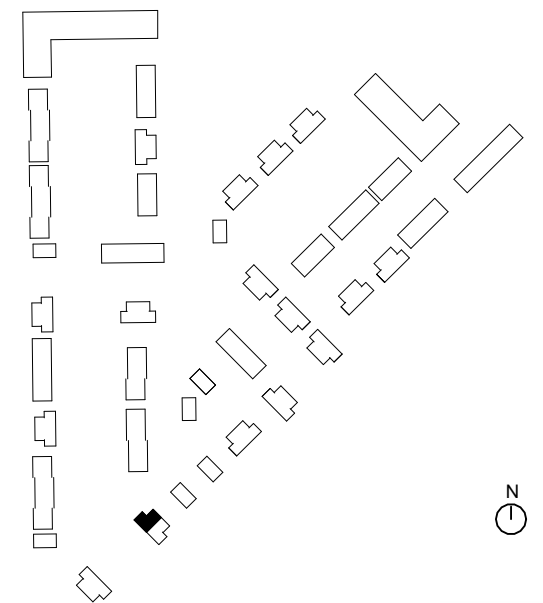

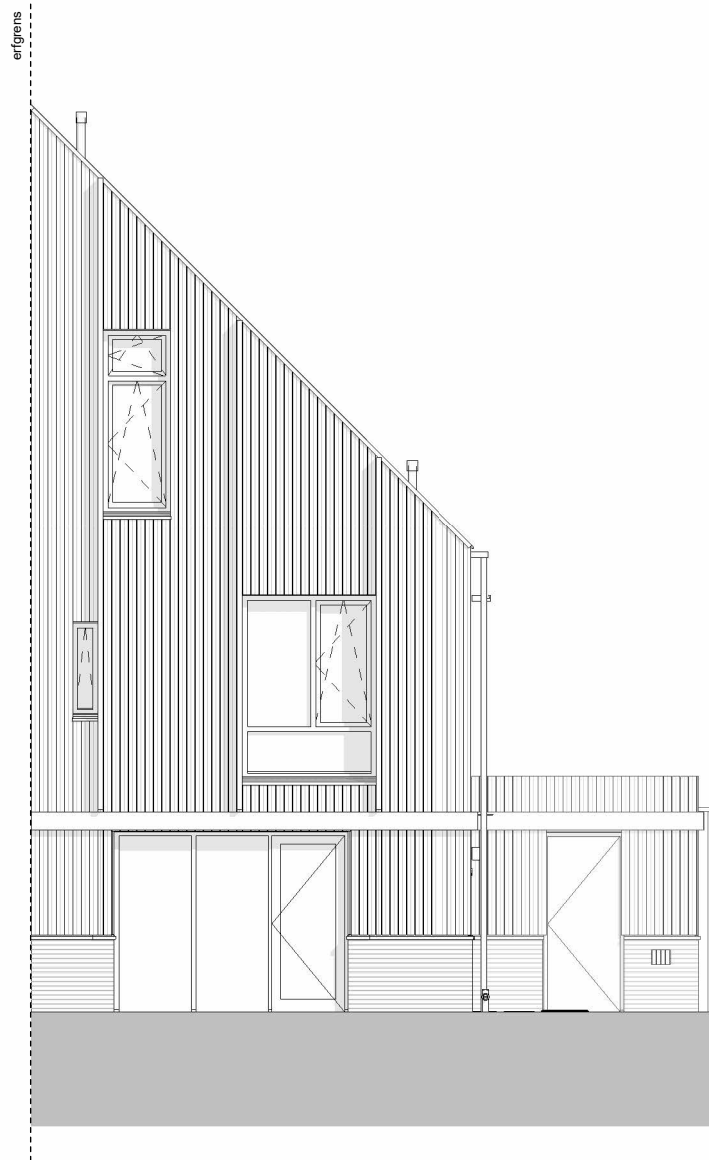

voorgevel (noordoost)

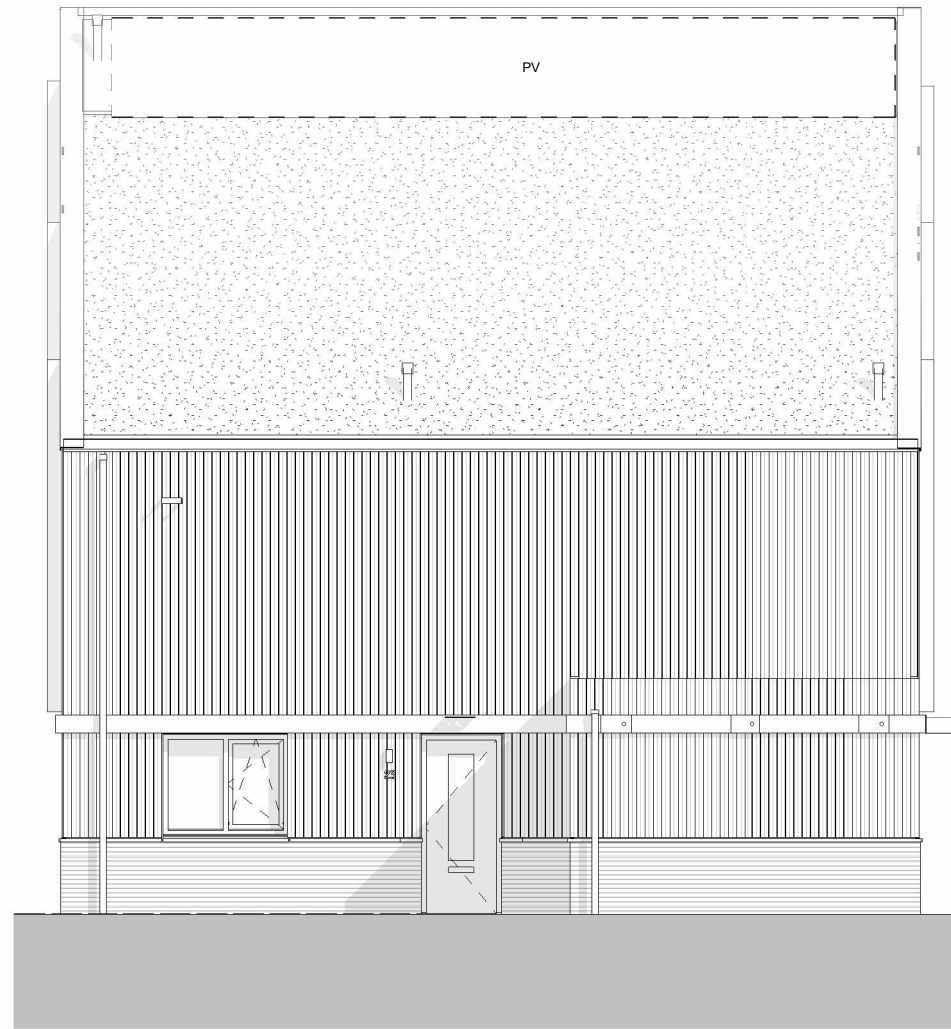

zijgevel (noordoost)

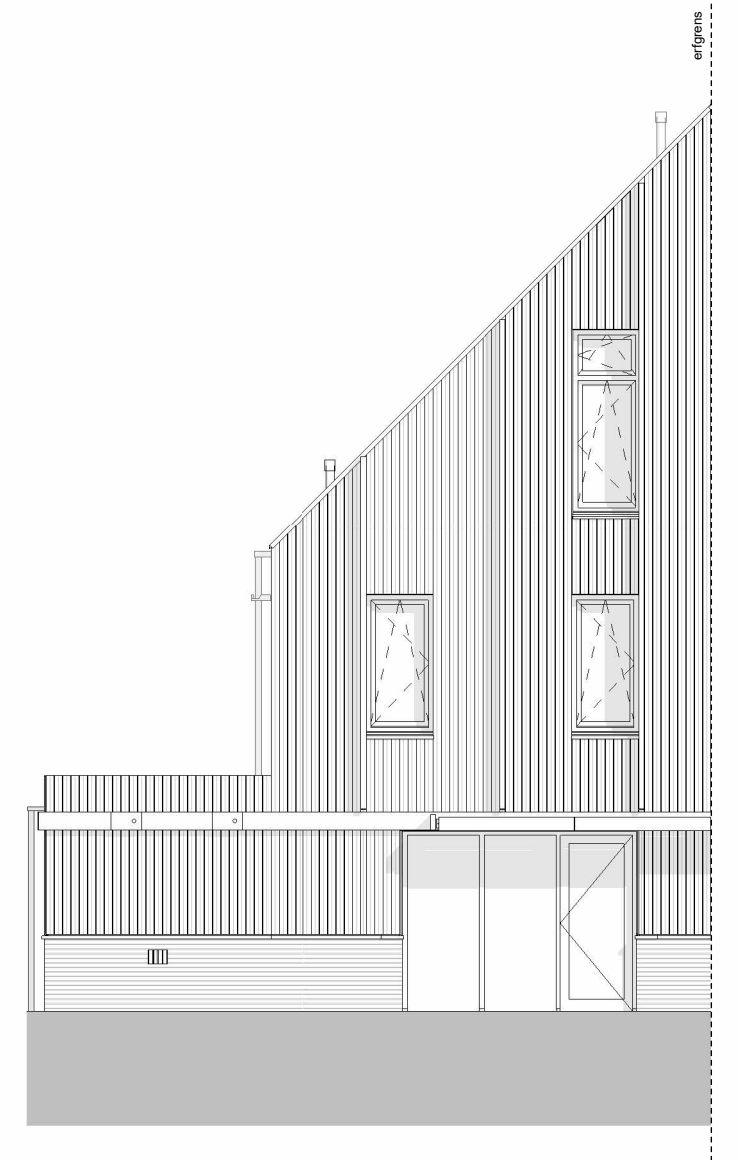

achtergevel (zuidoost)

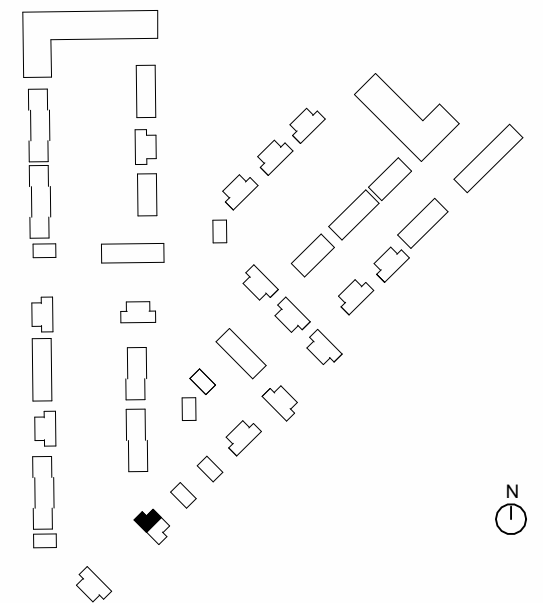

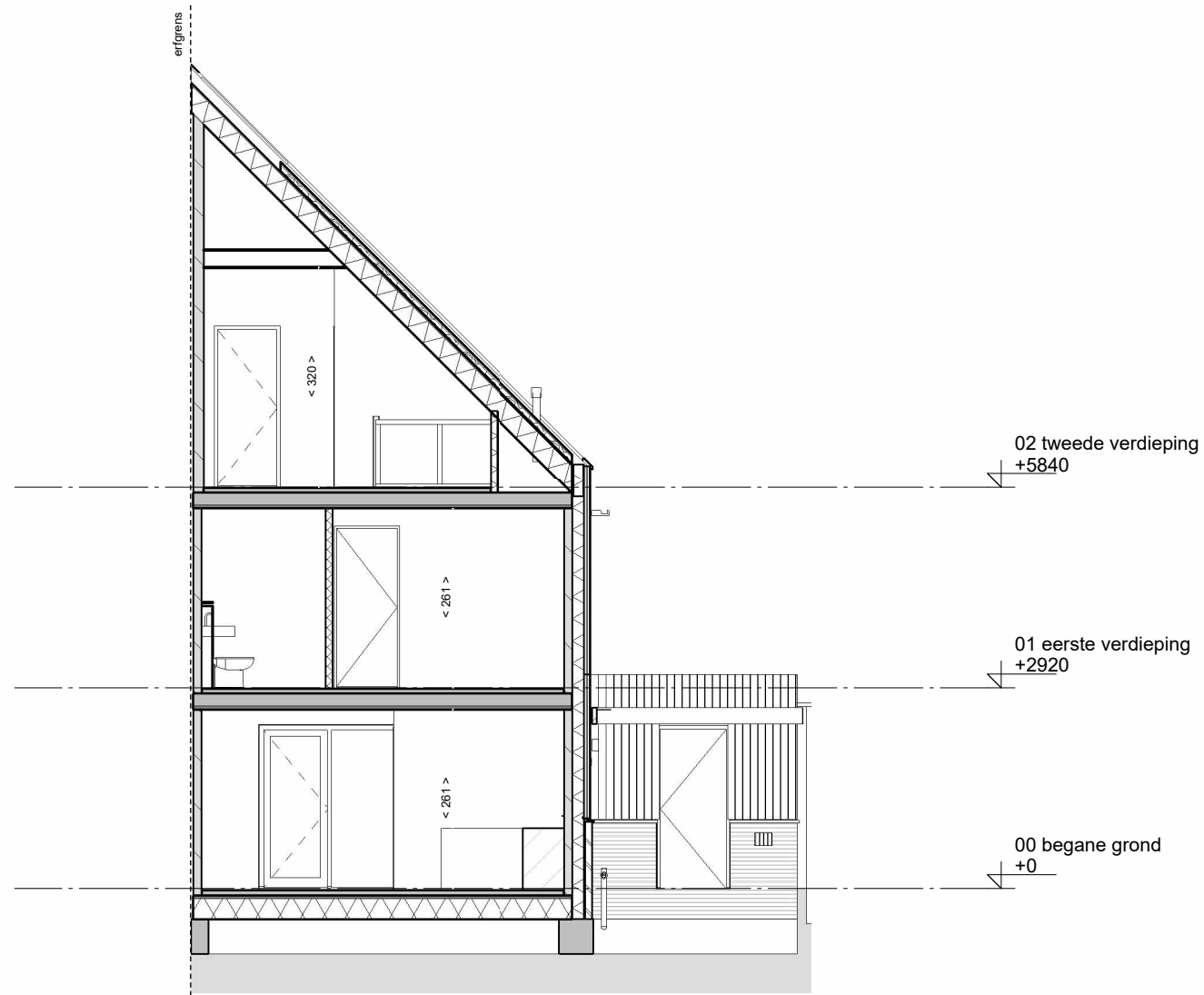

langsdoorsnede

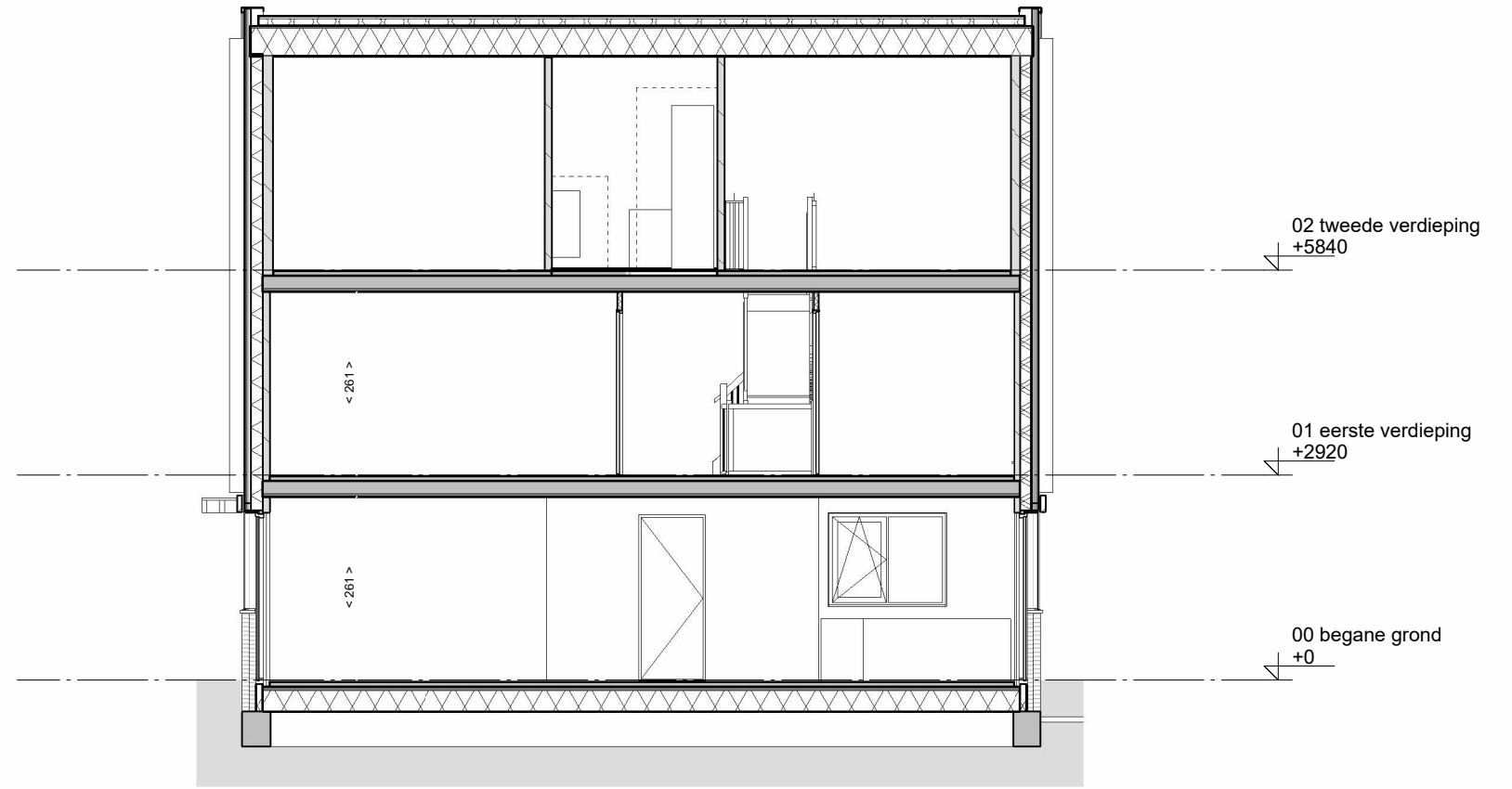

dwarsdoorsnede

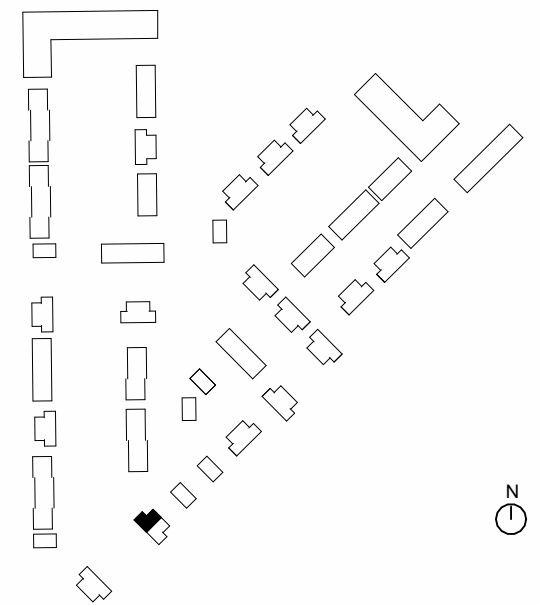

Omschrijving
Doorsnedes

voorlopig

Onderdeel
Verkooptekening

tekeningnummer
VK-015-3

Bouwnummer(s)
15 (2K)

getekend
-

schaal
1 : 100

formaat
A3

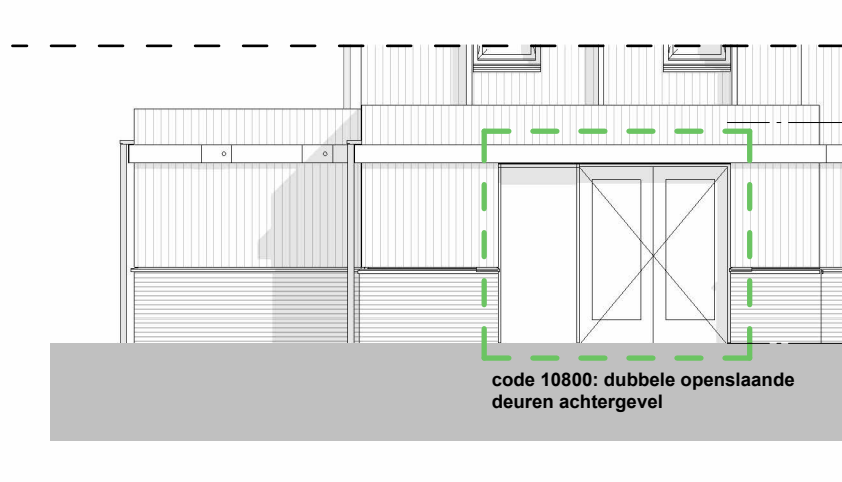

code 10140: uitbouw achtergevel 120cm

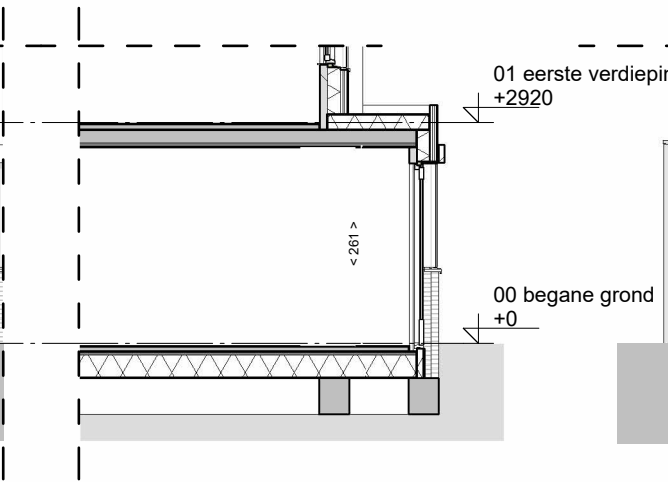

code 10140 / 50: uitbouw achtergevel 120cm

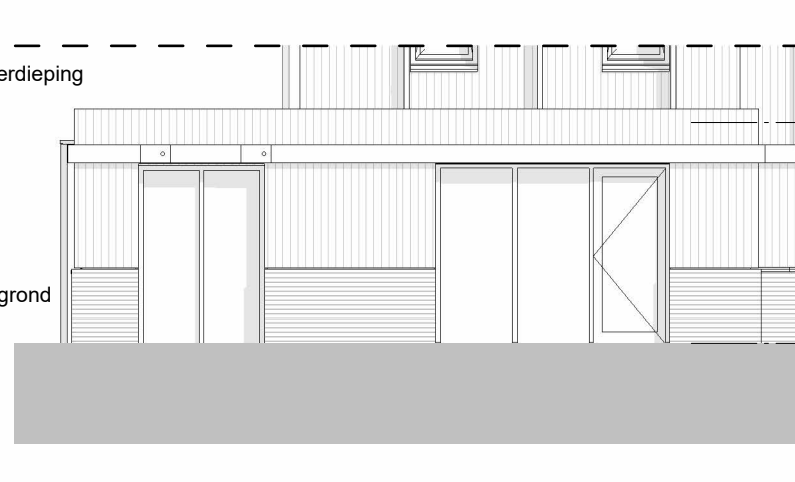

code 10150: uitbouw achtergevel en berging 120cm

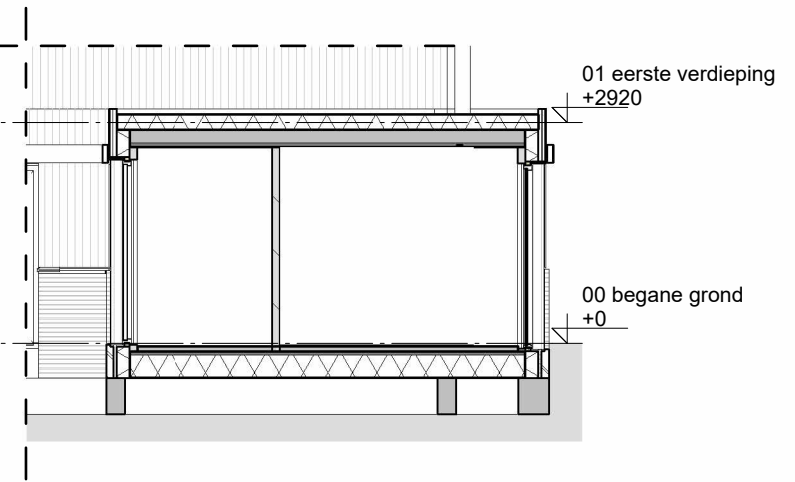

code 10120: uitbouw achtergevel en berging 120cm

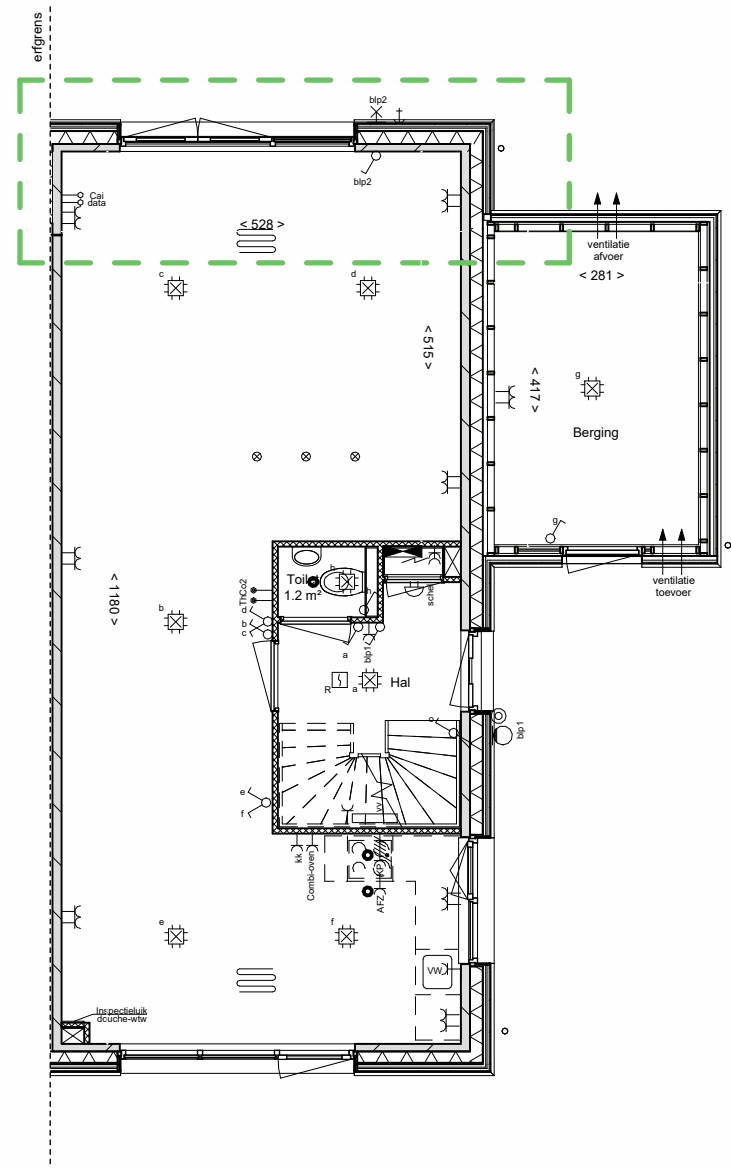

begane grond

code 10140: uitbouw achtergevel 120cm

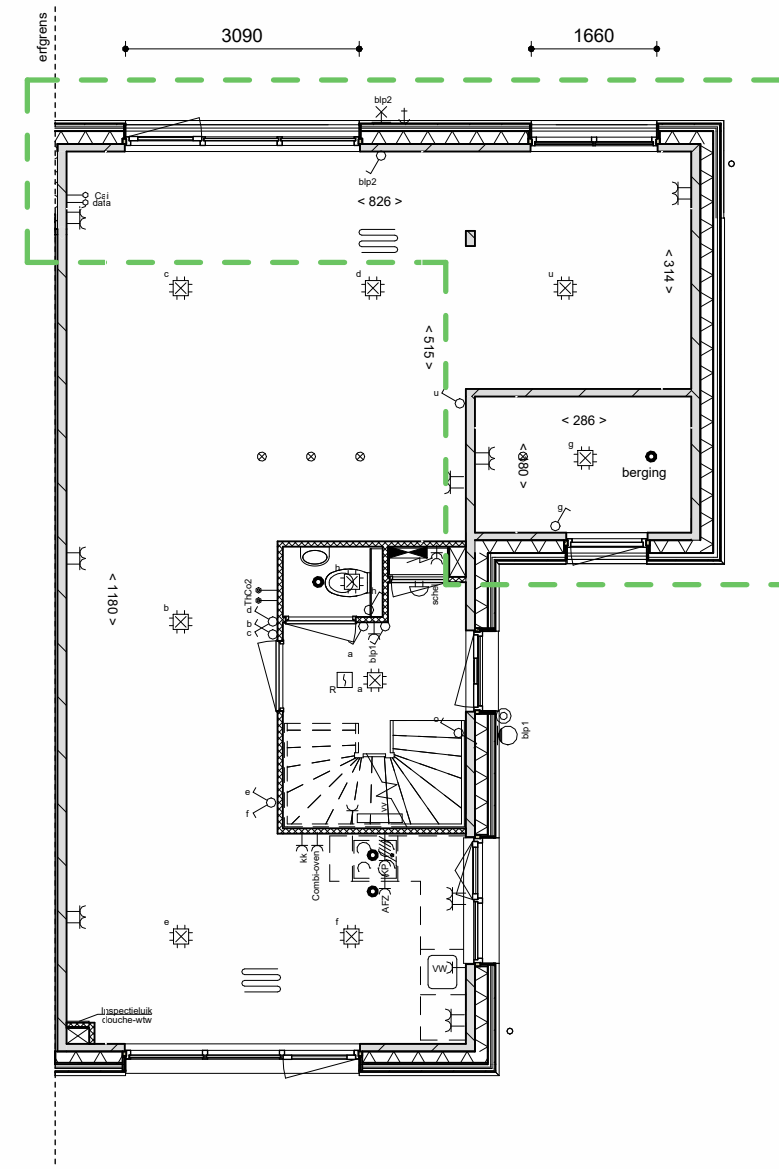

begane grond

code 10150: uitbouw achtergevel en berging 120cm

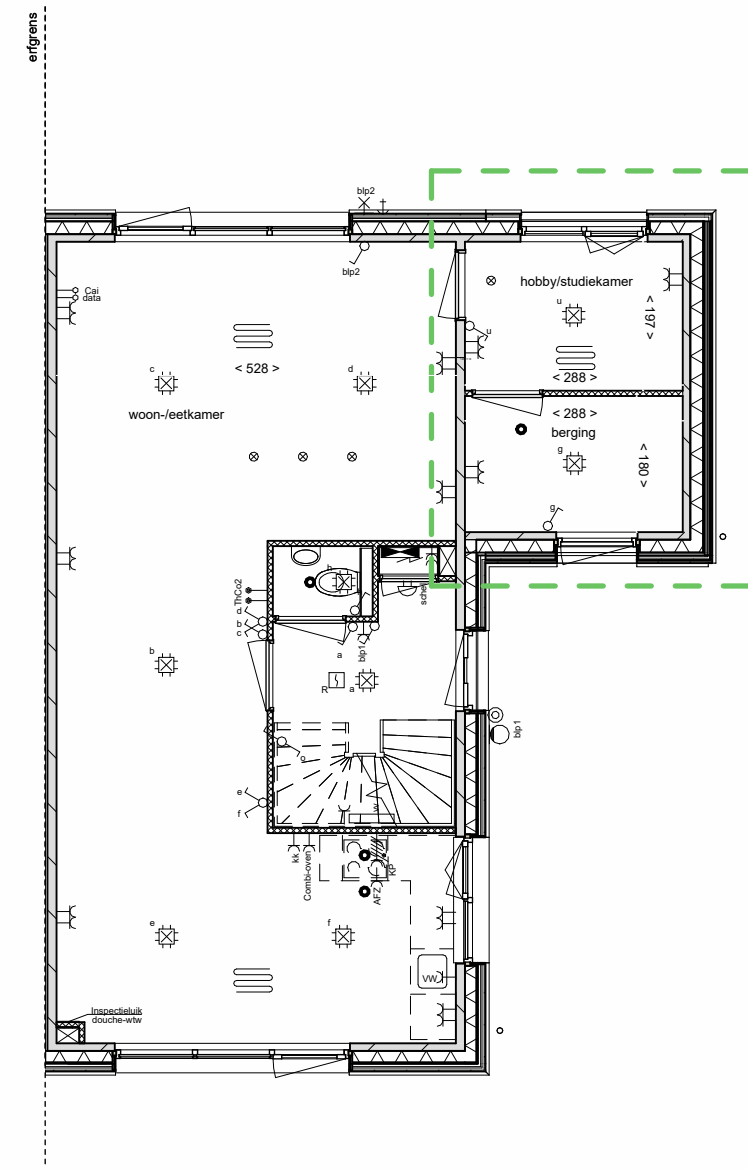

begane grond

code 12010: splitsing berging

NB:
Kopersopties slechts ter indicatie van de extra ruimte en bijbehorende gevelopeningen; materialisatie van de gevel (hout of metselwerk) wijkt mogelijk af van uw bouwnummer.

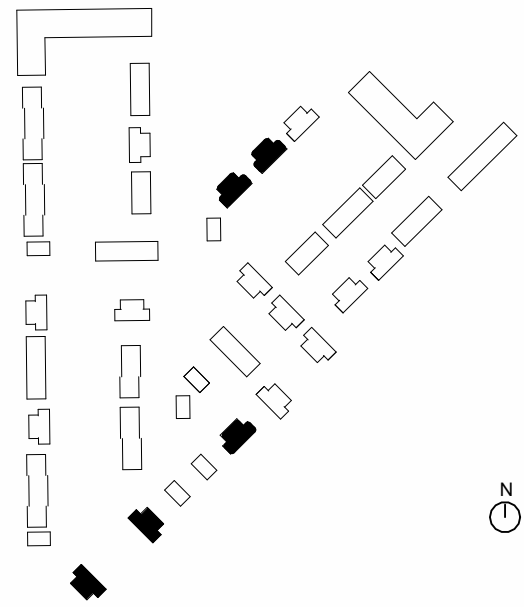

Omschrijving	Optietekening		
Onderdeel	tekeningnummer	VK-014-4	
Verkooptekening	getekend	schaal	formaat
Bouwnummer(s)	-	1 : 100	A3
10,11,14-17,105-108	-		

voorlopig

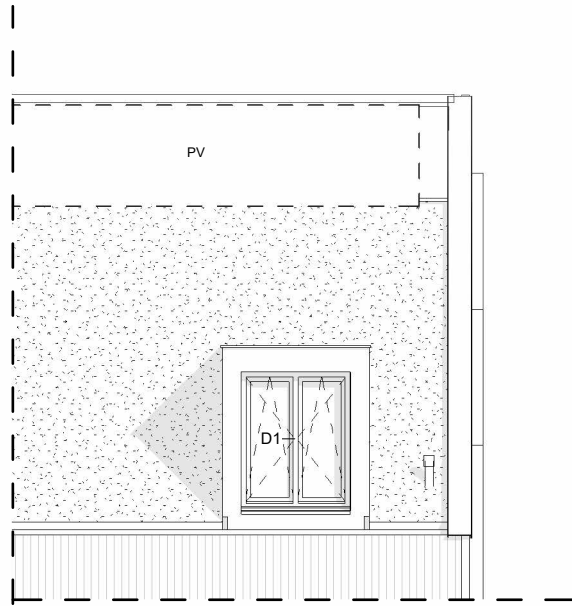

code 10510: dakkapel

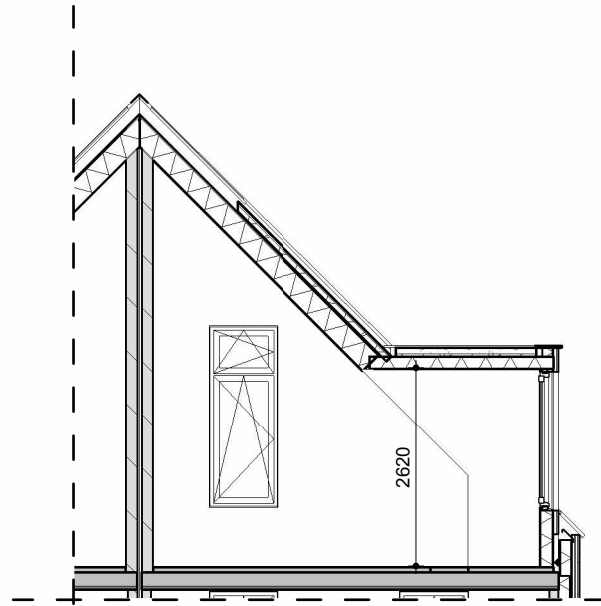

code 10510: dakkapel

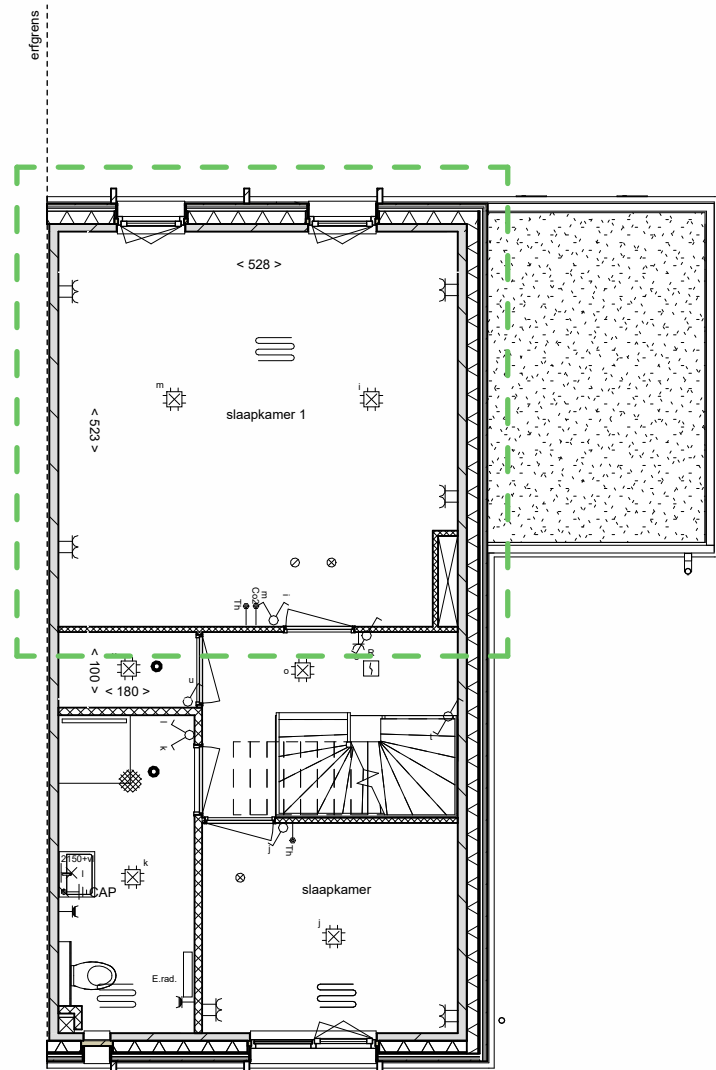

eerste verdieping

code 12145: samengevoegde slaapkamers

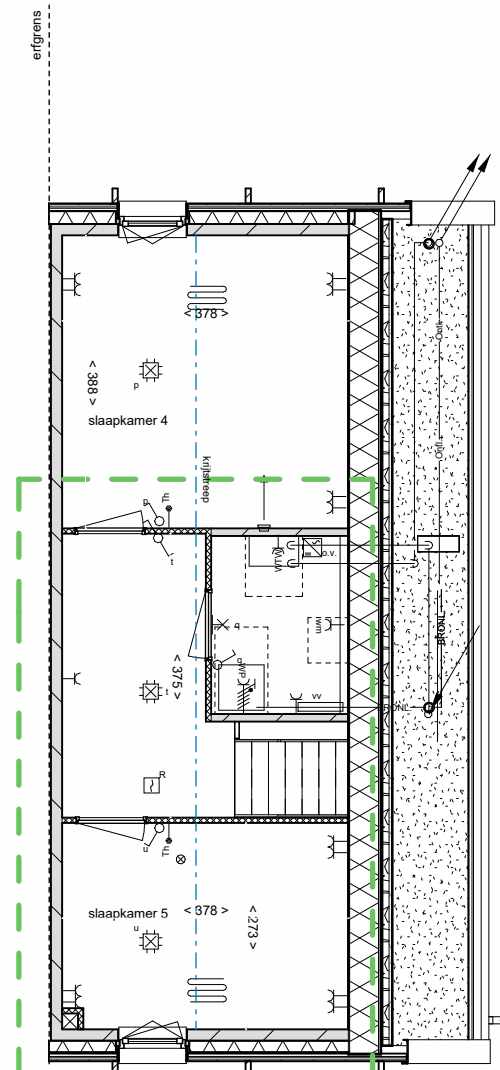

zolder

code 12410: splitsing zolder

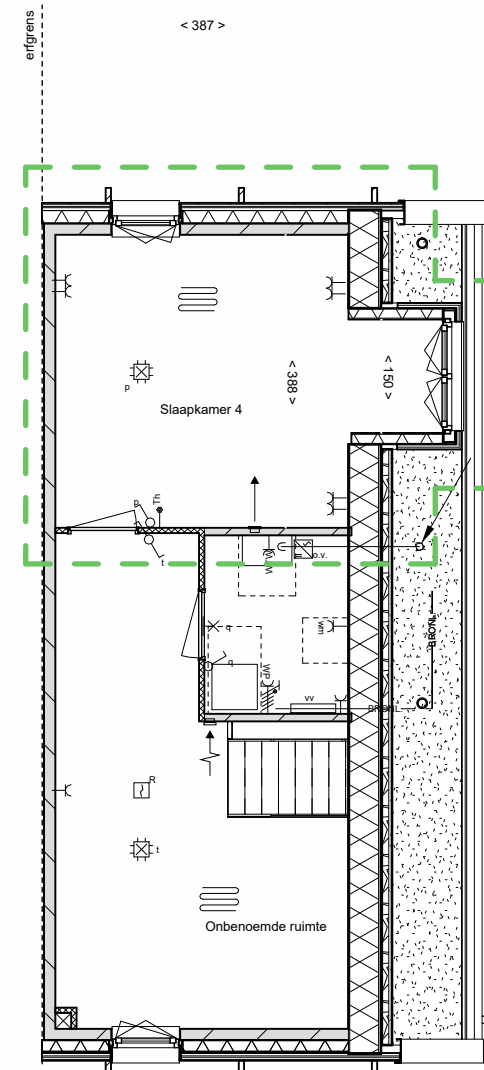

zolder

code 10510: dakkapel

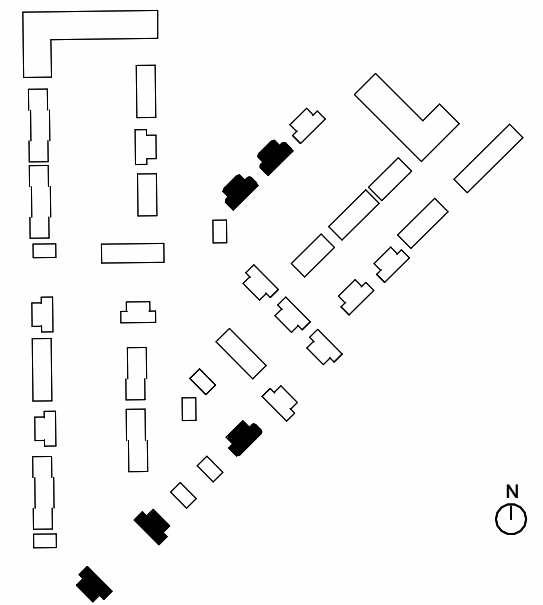

NB:
Kopersopties slechts ter indicatie van de extra ruimte en bijbehorende gevelopeningen; materialisatie van de gevel (hout of metselwerk) wijkt mogelijk af van uw bouwnummer.



Omschrijving
Optietekening

voorlopig

Onderdeel	tekeningnummer	schaal	formaat
Verkooptekening	VK-014-5	1 : 100	A3
Bouwnummer(s)	getekend		
10,11,14-17,105-108	-		